



1.0 HEALTH, SAFETY & ENVIRONMENT POLICY

1.1 Policy

“Insert Company Name Here” is committed to ensuring the health, safety and welfare of all their employees, contractors, customers, and visitors to *the* site. It is also committed to maintaining environmentally friendly operation practices and to comply with WorksafeBC relevant standards and guidelines. **All levels of employees are to acquaint themselves fully with the contents of this policy statement to ensure compliance within their area of responsibility.**

“Insert Company Name Here” Occupational Health and Safety Program is the guide to safe operation for “Insert Company Name Here” This Occupational Health & Safety Program and applicable policies and procedures conform to the WorksafeBC Occupational Health and Safety Regulation, Workers Compensation Act, OHS Guidelines and the Canadian Environmental Protection Act.

1.2 Responsibilities

The “Insert Company Name Here” intends to provide a safe workplace by:

- Developing a comprehensive occupational health, safety, environment and welfare program;
- Assigning responsibility to all levels of management for compliance with all aspects of this program;
- Continuously identifying hazards in the workplace and either eliminating them or reducing the risk associated with them;
- Providing appropriate training, instruction and education to all employees; and
- Enforcing this policy equally among employees, contractors, customers and visitors.

“Insert Company Name Here” Supervisors are responsible for:

- Providing a health and safety orientation to new workers;
- Providing ongoing training to workers;
- Taking part in inspections and investigations;
- Reporting any safety or health hazards; and
- Correcting unsafe acts and conditions.

All employees have a duty to maintain vigilance and foresight in identifying and correcting hazards to health, safety or the environment. When necessary, they are to contact their Supervisor to take the appropriate steps to eliminate or reduce mitigate hazards at work. “Insert Company Name Here”, the Employee Safety Representative and Management will be contacted where doubt or uncertainty may exist with respect to appropriate actions to be taken.

1.3 Commitment Statement

By placing my signature below, I personally endorse this policy and expect that all employees have the same high level of commitment that I do to the health, safety and welfare of our employees, contractors, customers, visitors, clients and the general public at large.

Signature: _____

Date: _____



4.0 ACCIDENT – INCIDENT INVESTIGATIONS POLICY

4.1 Purpose

The purpose of this policy and investigating accidents and incidents is to prevent a recurrence of the hazardous condition causing the event. This policy presents a practicable approach to investigating workplace accidents and incidents by emphasizing how to find the root cause(s), conduct an investigation, and make effective recommendations to prevent similar occurrences from ever happening again.

“Insert Company Name Here” will investigate serious accidents as well as any incidents that:

- a. Result in an injury or illness to a worker requiring medical treatment;
- b. Did not involve injury or illness to a worker, or involved only minor injury not requiring medical treatment, but had a potential for causing serious injury or illness to a worker;
- c. Occur resulting in loss or damage sustained to material, equipment or property.

Accident and Incidents in the workplace will be investigated for the following purposes:

- a. To fulfill legal requirements;
- b. Determine the cause of accidents and incidents;
- c. To ascertain compliance with applicable safety regulations;
- d. To determine the cost of an accident, and
- e. To determine what happened and why, so the steps can be taken to prevent a recurrence.

4.2 Definitions

“Accident” means an unplanned event that interrupts the completion of an activity, and that may (or may not) include injury or property damage.

“Incident” means an unexpected event that did not cause injury or damage this time but had the potential. “Near miss” and “dangerous occurrence” are also terms for an event that could have caused harm but did not.

4.3 Policy

1. The Supervisor, employees and/or the Safety Representative with appropriate training in conducting accident investigations must complete an accident / incident investigation.
2. The following steps shall be taken to adequately complete an incident investigation:



- a. Report the accident and/or incident occurrence to the Supervisor immediately;



7.0 DRUG AND ALCOHOL USE POLICY

7.1 Purpose

“Insert Company Name Here” will ensure to help provide a safe and drug-free work environment for their employees.

7.2 Policy

1. It is the policy of “Insert Company Name Here” that employees do not consume illegal drugs or alcohol while on the company premises and before or during work hours where being under the influence of these substances could affect the safety of work being performed.
2. This policy also enforces and explains the circumstances of the consumption of drugs or alcohol may affect work performance and safety many hours after they were last consumed. This may mean that a worker may still be impaired in the morning following ingestion.
3. “Insert Company Name Here” explicitly prohibits:
 - a. The use, possession, solicitation for, or sale of narcotics or other illegal drugs, alcohol, or prescription medication without a prescription on “Insert Company Name Here” premises.
 - b. Being impaired or under the influence of legal or illegal drugs or alcohol at work or away from “Insert Company Name Here” premises, if such impairment or influence adversely affects the employee's work performance or the safety of the employee or of others.
4. If there is a confirmation or a strong suspicion by a Supervisor that an employee is in violation of this policy - the employee will not be allowed to work and sent home **via a taxi service only and paid for by “Insert Company Name Here”**
5. Such an incident will be subjected to appropriate disciplinary action, up to and possibly including discharge from employment.
6. In such a case, the employee will be given an opportunity to explain the circumstances prior to any final disciplinary or employment action becoming effective.

7.3 Medications

In the interest of health and safety, employees who require the use of a Medication that may result in their not being Fit for Duty shall:

- a. Investigate, where appropriate, (through their medical professional) whether the Medication can negatively impact their ability to safely and acceptably perform assigned duties.



8.7 Pictograms (2015)

Chemicals that fell under the 1988 WHMIS legislation were called “controlled products”. However, under the 2015 WHMIS legislation “controlled products” will now be called “**Hazardous Products**”. The 2015 hazard symbols are now called **PICTOGRAMS** and will be enclosed inside of a **RED** colored **DIAMOND** shape.

In 2015 three symbols have changed their representation/identity compared to the 1988 WHMIS legislation. These three symbols are “Exploding Bomb”, “Health Hazard” and “Exclamation Mark”. The “Biohazardous Infectious Materials” symbol will still remain the same and will still be enclosed inside of a **BLACK** colored **CIRCLE** shape.

The “Environment” symbol has been added to the 2015 WHMIS legislation which means the hazardous products may cause damage to the aquatic environment (i.e. spray painting, accidental spill, etc.)

	Exploding bomb (for explosion or reactivity hazards)		Flame (for fire hazards)		Flame over circle (for oxidizing hazards)
	Gas cylinder (for gases under pressure)		Corrosion (for corrosive damage to metals, as well as skin, eyes)		Skull and Crossbones (can cause death or toxicity with short exposure to small amounts)
	Health hazard (may cause or suspected of causing serious health effects)		Exclamation mark (may cause less serious health effects or damage the ozone layer*)		Environment* (may cause damage to the aquatic environment)
	Biohazardous Infectious Materials (for organisms or toxins that can cause diseases in people or animals)				

* The GHS system also defines an Environmental hazards group. This group (and its classes) was not adopted in WHMIS 2015. However, you may see the environmental classes listed on labels and Safety Data Sheets (SDSs). Including information about environmental hazards is allowed by WHMIS 2015.

8.9 Safety Data Sheets – SDS (2015)

Under the 2015 WHMIS legislation, Safety Data Sheets will **NOT** be required to be updated every 3 years. Instead, SDS’s will be updated when significant new data become available.



In the 1988 WHMIS legislation, the minimum sections required in a Safety Data Sheet were 9 sections. In the 2015 WHMIS legislation, the minimum sections required in a Safety Data Sheet will be **16 sections**.

1. Identification (product and supplier)	9. Physical and chemical properties
2. Hazard identification	10. Stability and reactivity
3. Composition/information on ingredients	11. Toxicological information
4. First-aid measures	12. Ecological information*
5. Fire-fighting measures	13. Disposal considerations*
6. Accidental release measures	14. Transport information*
7. Handling and storage	15. Regulatory information*
8. Exposure controls/ personal protection	16. Other information

* Sections 12 to 15 require the headings to be present. The supplier has the option to not provide information in these sections.

The definition of each of the 16 sections are as follows:

1. *Identification*

Product identifier, recommended use and restrictions on use, supplier contact information, emergency phone number.

2. *Hazard Identification*

Classification (hazard class and category), label elements (including hazard pictogram, signal word, hazard statement and precautionary statements) and other hazards (e.g. thermal hazards).

3. *Composition/Information on Ingredients*

For a hazardous product that is a substance: the chemical name, synonyms, CAS No. and the chemical name of impurities, stabilizing solvents and stabilizing additives where classified and that contribute to the classification of the product. For a hazardous product that is a mixture: for ingredients that present a health hazard, the chemical name, synonyms, CAS No. and concentration. Note: Confidential Business Information Rules may apply.

4. *First-aid Measures*

First-aid measures by route of exposure as well as most important symptoms/effects.

5. *Fire-fighting Measures*

Suitable (and unsuitable) extinguishing media, specific hazards, special equipment and precautions for fire fighters.

6. *Accidental Release Measures*

Protective equipment, emergency procedures, methods and materials for containment and clean up.



19.7 Manufactured Components

1. Major components of scaffolds must be used in accordance with technical data provided by the manufacturer, or in writing by a professional engineer, that:
 - a. shows the rated load, erection procedures and compliance with the OHS Regulations, and
 - b. is available at the workplace for reference.

19.8 Lumber for Structural Components

All lumber used to construct a scaffold must be graded and marked to the National Lumber Grades Authority Standard Grading Rules for Canadian Lumber.

19.9 Scaffold Stability

1. A scaffold must be erected with the vertical members plumb, and with the ledgers and bearers level.
2. The base of a scaffold must have bearing plates or sills that rest on a solid surface and are sufficient to support the weight of the scaffold.
3. The poles, legs and uprights of a scaffold must be securely and rigidly braced to prevent movement.
4. A scaffold must be effectively guyed or secured to a building or structure:
 - a. if the height of the scaffold exceeds 3 times its minimum base dimension, or
 - b. in any other circumstances if required for stability.
 - c. Unless otherwise specified by the manufacturer, height adjustment devices must not extend more than 2/3 of their total length or 60 cm (24 in), whichever is less.

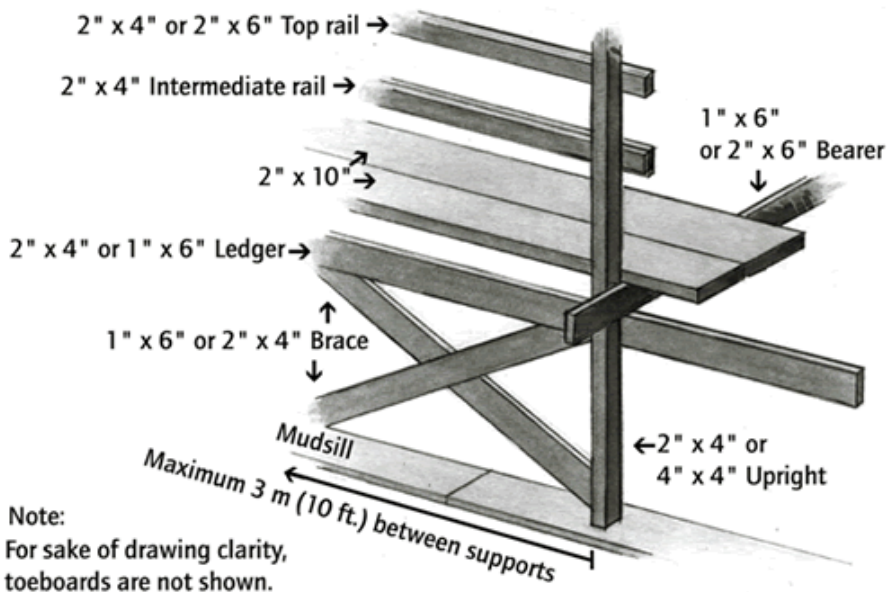
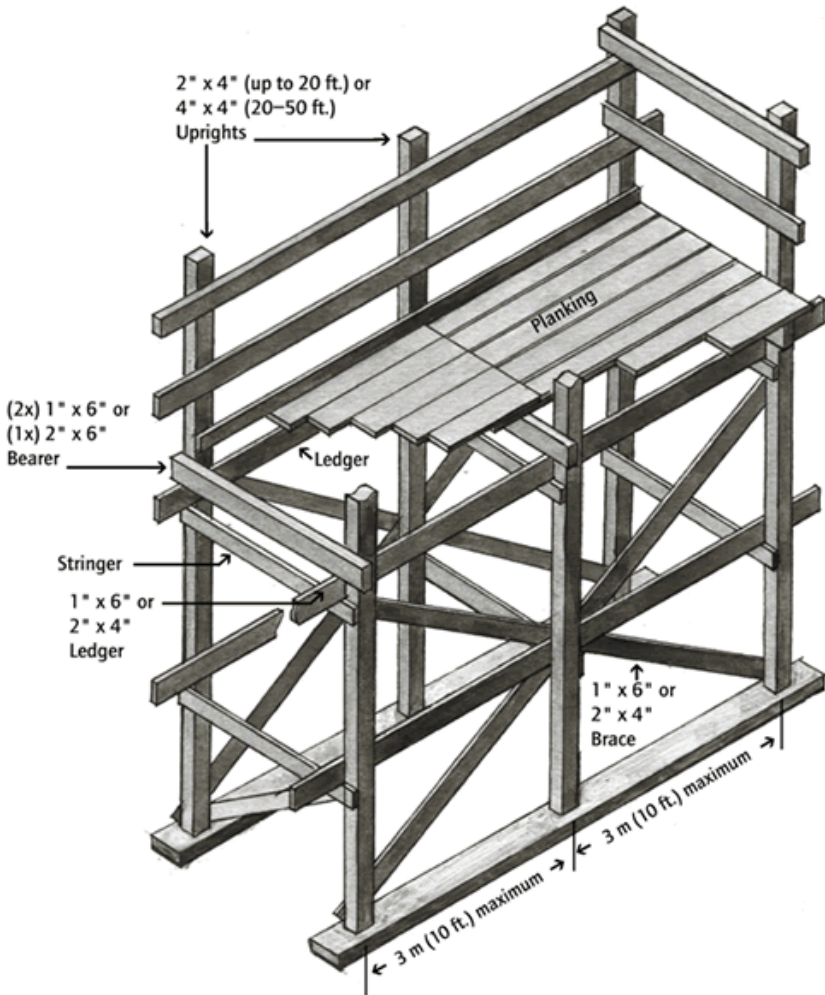

Note:
For sake of drawing clarity,
toeboards are not shown.



25.0 CONFINED SPACE ENTRY POLICY

25.1 Purpose

To insure the safety of services personnel by establishing definitions of confined spaces and qualifications for entry

25.2 Scope

This program applies to all “Insert Company Name Here” employees required to enter a confined space.

25.3 Definitions

“Authorized Entry Worker”: In respect of a specific duty, a worker who, because of knowledge, training and experience, is capable of performing that duty safely and properly.

“Blanking”: The absolute closure of a pipe, line, or duct by the fastening of a solid plate that completely covers the bore and that is capable of withstanding the maximum pressure of the pipe, line or duct with leakage beyond the plate.

“Confined Space”: A fully or partially enclosed space that is not primarily designed or intended for human occupancy and in which, because of its construction, location or contents or work activity therein, the accumulation of a hazardous gas, vapour, dust or fume or the creation of an oxygen-deficient atmosphere may occur.

“Confined Space Entry Permit”: The permit that provides authorization to an Authorized Entry Worker to enter a confined space (Program Attachment A).

“Control Plan” A confined space entry and hazard control plan which includes methods, procedures and practices for controlling all hazards identified by an assessment of the hazards to which the confined space entrants may be exposed (Program Attachment B).

“PPM”: Parts per million

“Purging”: Displacing contaminants from a confined space

“Safe Atmosphere”: An atmosphere where:

- (a) the oxygen content of the atmosphere remains at least 19.5% but not more than 23% by volume; and
- (b) the atmospheric concentration of any explosive or flammable gas or vapour does not exceed 10% of the lower explosive limit or 10% of the lower flammable limit of the gas or vapour;

“Retrieval System”: The equipment (including a retrieval line, chest or full body harness, wristlets, if appropriate, and a lifting devise or anchor) used for non-entry rescue of persons from a confined space.

“Tending Worker / Safety Monitor”: A worker outside a confined space that is trained and monitors the activities of the Authorized Entry Worker and who is able to provide assistance to workers occupying the confined space and who is able to summon assistance in order to initiate a rescue of such workers if required.



25.4 Authorized Entry Worker

1. Shall be fully trained in the identification and in the hazards associated with entering confined spaces, applicable legislation and the requirements of this program.
2. Shall only enter a confined space following proper authorization as outlined in this program.
3. Shall comply with all requirements of this program and all personal protective equipment requirements deemed necessary by the Supervisor, Manager or Designate.
4. Shall comply with the instructions of the Supervisor, Manager or Safety Monitor during the confined space entry.

25.5 Supervisor or Manager of an Authorized Entry Worker

1. Shall be fully trained in the identification and in the hazards associated with entering confined spaces, applicable legislation and the requirements of this program.
2. Identify authorized or qualified employees to work or support those who work in a confined space.
3. Ensure that all employees involved in confined space operations have the training as required by this program.
4. Authorize confined space entry permits.
5. Ensure that the conditions of this program are met during all confined space entries.
6. Apprise any contractor performing work in a confined space of our requirements prior to entry and ensure that these requirements have been met.
7. Verify that all tests specified by the permit have been conducted and that all procedures and equipment specified by the permit are in place before endorsing the permit and allowing entry to begin.
8. Verify that rescue services and retrieval systems are available and that the means for summoning them are operable prior to authorizing entry.



18.0 NEW AND YOUNG EMPLOYEE ORIENTATIONS POLICY

18.1 Instruction and Supervision: Purpose

1. Young and new workers need special attention because they are at more risk of injury than their older or more experienced counterparts.
2. It is “Insert Company Name Here” responsibility to ensure that every worker receives adequate education and training (instruction) to do their work safely.
3. All employees must strictly adhere to the contents and provisions of “Insert Company Name Here” Occupational Health & Safety Program, WorksafeBC Occupational Health and Safety Regulation and Workers Compensation Act and all other applicable regulations.

18.2 Policy

1. “Insert Company Name Here” shall provide training and orientation to all new and young workers (a worker 25 years old, or younger is considered a young worker):
 - a. Before they start work; or
 - b. When they come from another work location; or
 - c. When there’s been a change in the workplace that could affect their wellbeing.
2. All “Insert Company Name Here” employees, including new and young employees, will be given a safety orientation by their Supervisor immediately upon hiring.
3. “Insert Company Name Here” will make sure the new or young worker understands the training by asking questions about specific procedures or general requirements and by constant observation.
4. All new and young worker education, training and orientations must be recorded on the **“Insert Company Name Here” Training Record Form and the New & Young Worker Orientation Form.**
5. All education, training and orientation records shall be maintained for each worker, listing topics covered and date of education or training

18.3 Purpose

The purpose of this policy is to ensure that “Insert Company Name Here” has established procedures for reporting potential or actual hazards and/or unsafe conditions and behaviors throughout the work site.

18.5 Definitions

“Hazard” A thing or condition that may expose a person to a risk of injury or occupational disease.

“IDLH” Immediately Dangerous to Life or Health.



18.4 Policy

1. If safe to do so rectify or remove any hazard(s) or unsafe condition(s) immediately. Examples of these hazards can be from tripping, slipping, and/or blocked access or egress. Ensure the hazard being rectified can be done so in a safe manner, where the health and safety of an employee(s) is not at risk.
2. If the hazard, unsafe condition and/or unsafe behavior is not rectifiable in a safe manner, the hazard should be reported to their Supervisor immediately and/or the store Safety Representative.
3. If a hazard is IDLH (immediately dangerous to life or health) ensure your own safety and secure the area until the Supervisor has been contacted and measures have been taken to rectify the hazard.
4. Hazards, unsafe conditions and/or unsafe behaviors can be reported to their Supervisor verbally or by filling out the **“Insert Company Name Here” Incident Investigation Report** form and forwarding to their Supervisor.
5. This policy does not preclude employees from exercising their right to refuse unsafe work as mentioned in ‘right to refuse unsafe work’ **“Insert Company Name Here”** policy and the WorksafeBC Occupational Health and Safety Regulation and Workers Compensation Act.

18.5 Supervisor Responsibility

1. The Supervisor must ensure that all hazard reports are responded to and investigated immediately.
2. Ensure work does not resume until the hazard is controlled and rectified and no longer presents an unacceptable risk to the health and safety of employees.
3. Ensure all applicable sections of the **“Insert Company Name Here” Incident Investigation Form** are filled out.
4. All hazard reports and incident investigation reports will be reviewed and discussed on a monthly basis by the Supervisor and the Safety Representative.

18.6 Instruction and Supervision: Right to Refuse Unsafe Work

1. The purpose of this policy is to ensure that every **“Insert Company Name Here”** employee has the right to refuse work if he or she feels it is unsafe.
2. **“Insert Company Name Here”** will continue to maintain a safe work environment for its employees in order to prevent occupational injuries and illnesses.



19.0 SUB-CONTRACTOR HIRING POLICY

19.1 Purpose

It is the contractor's responsibility to ensure that project work is performed in a safe manner, and that it is in compliance with Provincial Occupational Health and Safety Regulations, any other applicable provincial and/or federal laws and/or regulations, and any "Insert Company Name Here" policies, procedures and other requirements that may apply.

"Insert Company Name Here" expectations are that contractors will train, supervise, and direct their contractors to be mindful of the safety of "Insert Company Name Here" contractors and visitors when performing work on "Insert Company Name Here" premises.

19.2 Contractor Safety Programs

1. The Prime Contractor shall have in place a safety program acceptable to WorksafeBC.
2. The implementation of the safety program shall be monitored through monthly safety meetings with the Prime Contractor, contractors and subcontractors.
3. Minutes of these meetings shall be forwarded to "Insert Company Name Here" and posted at the site office for view by the public.
4. The Prime Contractor shall report the following to the "Insert Company Name Here" Project Manager:
 - a. Immediate notification of incidents or near misses that resulted or could have resulted in injuries requiring medical care.
 - b. Results of any accident investigations.
 - c. Safety committee meetings held.
 - d. Inspections performed.

19.3 Contractor Site Safety Plan

1. The responsibility for safety shall rest with the Prime Contractor.



2. The requirements of Provincial Occupational Health and Safety regulations, the Provincial Traffic Control Manual, the Provincial Building Code and the Provincial Fire Code apply as a minimum.
3. All contractors and sub-contractors must be registered employers with WorkSafeBC and have WorkSafeBC Insurance for all their workers.
4. The owner will provide the Prime Contractor with any information known to the owner that is necessary to identify and eliminate or control hazards to the health or safety of persons at the workplace.
5. The Owner Representative will deal with issues of non-compliance and apply any consequences directly to the contractor or prime contractor.
6. As a minimum, contractors must:
 - a. Provide any safety documentation necessary to meet “Insert Company Name Here” requirements.
 - b. Be experienced in all phases of the work to be done.
 - c. Ensure their workers on the project are adequately trained in the work procedures to be used.
 - d. Exercise good site safety management

19.4 Employer and Contractor Responsibilities

19.5 “Insert Company Name Here” Responsibilities

Our responsibility is to help contractors coordinate health and safety activities by:

- a. Providing contractors with information on all workplace hazards in your work areas;
- b. Ensuring the requirements of the Workers Compensation Act and Provincial Occupational Health and Safety Regulation are met; and
- c. Ensuring a system is in place to evaluate a contractor’s safety program and safe work procedures, before commencing onsite work (if required).



FALL PROTECTION EQUIPMENT INSPECTION CHECKLIST

Print Name: _____

Date of Inspection: _____

Signature: _____

Other: _____

This checklist is a guideline for your daily fall protection equipment inspection. You have been trained on how to thoroughly inspect your fall protection equipment to ensure your personal safety.

- Put a check mark in the boxes if the corresponding equipment is in good working order.
- Put a in the boxes if the corresponding equipment is **NOT** in good working order.
- **REPORT ALL DEFECTIVE EQUIPMENT TO YOUR SUPERVISOR AND ENSURE ALL DEFECTIVE EQUIPMENT IS DESTROYED AND/OR TAGGED OUT OF SERVICE.**

FULL BODY HARNESS	<input checked="" type="checkbox"/> <input type="checkbox"/>	LANYARD	<input checked="" type="checkbox"/> <input type="checkbox"/>
Tags and Labels: be sure model and serial numbers are clear as well as CSA approval and manufacture date.		Webbing: no fraying, cuts, burns or chemicals. Stitching is good. No knots. Wear indicators if present.	
Webbing: webbing frayed, cut or burned. Wear indicators good. No glue, paint or other chemicals.		Snap Hooks: bent, cracked, corroded or twisted hook. Lock functioning. Springs working.	
Tongue, Grommets and Buckles: not bent, cracked or corroded. All parts move freely. No distortion or sharp edges. Grommets good, none missing or damaged.		Shock Absorber: check for signs for signs of deployment, shock loading. Stitching where pack is attached.	
Seams or Stitching: stitching loose, pulled, ripped or worn. Check load bearing and attachment stitching carefully.		LIFELINE	<input checked="" type="checkbox"/> <input type="checkbox"/>
D Rings: not worn, bent or deformed. No rough or sharp edges. Rings pivot freely. Check closely for cracks.		Rope: frayed, rotted, cut or fuzzy. No knots. Discoloration from exposure or chemicals.	
Rivets & Straps Keepers: In good shape, not loose. Strap keepers move, not broken or missing.		Diameter: matches the rope grab and is uniform throughout	
Clean and Oil Free: Check with supervisor if in doubt of condition.		Attachment to Snap Hook: Original from manufacturer. Thimble good.	
Tool Holders: Safe and good shape, no modifications or damages.		Rope Grab: functioning properly. Check gate, locking pin, safety latch worn out teeth on cam, springs. Do hand test.	
SELF RETRACTING LIFELINE	<input checked="" type="checkbox"/> <input type="checkbox"/>	HORIZONTAL LIFELINE	<input checked="" type="checkbox"/> <input type="checkbox"/>
Line: pull out and inspect cable for bends, frayed strands, evidence or excessive wear. Retrieval / retraction mode functioning properly. Pull test to make sure it catches. Check for shock loading indicator. Attach directly to dorsal D ring.		Engineered: specifically designed and engineered for fall protection. Check for capacity (how many workers). Ask Supervisor to confirm if unsure.	

Type: _____

S/N: _____

Type: _____

S/N: _____

Type: _____

S/N: _____

Supervisor Signature: _____

Date: _____



EMERGENCY EVACUATION DRILL FORM

Year	Month	Day		Sector	Scenario	Involves*
			Scenario description: <i>*Involves – Fire Drill Evacuation; Actual Fire; “Supervisor” had a heart attack; “Worker” had heat exhaustion.</i>			
			Debrief – what worked well:			
			Debrief – what needs improvement:			

Corrective Action Log

#		Problem	Required Action	Who	By When	Done

Reviewed By (name/position)
Date



WORKING ALONE FORM

Definition

Alone

Working by yourself with no other people in the vicinity.

Isolation

Working in the same general area with a partner or another crew, but will not be in contact with the other person or crew for an extended amount of time.

Person Working Alone

- The person who will be working alone (the lone worker) must designate a contact person to check in with on a pre-planned schedule. The check in will be every _____ hours plus at end-of-shift.
- The lone worker must carry a functioning communication device, such as a satellite transceiver, two-way radio, satellite phone, cell phone or combination thereof plus the contact information for the contact person.
- The designated contact person must have a copy of this working alone procedure and any applicable ERP, contact information, locations and/or maps necessary for rescue of the lone worker.
- The designated contact person must record the time of each contact with the lone worker.
- If the lone worker fails to check in, then the contact person must initiate search procedures after _____ hours. See Missing Worker section of company Emergency Response Plan.

Person Working in Isolation

If two people are working on the same opening, or in the same immediate area, both should carry a functioning communication device and check in with each other on a predetermined schedule:

If neither person has a functioning communication device then visual contact must be made on a predetermined schedule at the predetermined location:

Supervisor Responsibilities

The supervisor has:

1. Identified hazards to the worker
2. Managed the identified risks from hazards
3. Trained the contact person in responsibilities including emergency response.



Working Alone or In Isolation Checklist

Date(s): _____

Worker Name: _____

Working Location: _____

Contact Person Name: _____

Radio Frequency 1 _____

Radio Frequency 2 _____

Emergency Contact

Type: _____
(family, supervisor, etc.)

Emergency Contact Phone: _____

Frequency of Contacts: _____

Monday		Tuesday		Wednesday		Thursday		Friday	
Time	Check	Time	Check	Time	Check	Time	Check	Time	Check
8:00 AM	<input type="checkbox"/>	8:00 AM	<input type="checkbox"/>	8:00 AM	<input type="checkbox"/>	8:00 AM	<input type="checkbox"/>	8:00 AM	<input type="checkbox"/>
10:00 AM	<input type="checkbox"/>	10:00 AM	<input type="checkbox"/>	10:00 AM	<input type="checkbox"/>	10:00 AM	<input type="checkbox"/>	10:00 AM	<input type="checkbox"/>
12:00 PM	<input type="checkbox"/>	12:00 PM	<input type="checkbox"/>	12:00 PM	<input type="checkbox"/>	12:00 PM	<input type="checkbox"/>	12:00 PM	<input type="checkbox"/>
2:00 PM	<input type="checkbox"/>	2:00 PM	<input type="checkbox"/>	2:00 PM	<input type="checkbox"/>	2:00 PM	<input type="checkbox"/>	2:00 PM	<input type="checkbox"/>
4:00 PM	<input type="checkbox"/>	4:00 PM	<input type="checkbox"/>	4:00 PM	<input type="checkbox"/>	4:00 PM	<input type="checkbox"/>	4:00 PM	<input type="checkbox"/>
End of shift		End of shift		End of shift		End of shift		End of shift	

Name of Person Conducting Checks: _____

Signature of Person Conducting Checks: _____



CONFINED SPACE ENTRY PERMIT

NAME OF SPACE:		
DATE OF ENTRY:	TIME ENTRY START:	
DATE OF EXPIRY:	TIME PERMIT EXPIRES:	
NAME OF STANDBY PERSON (1)	TIME START:	TIME STOP:
NAME OF STANDBY PERSON (2)	TIME START:	TIME STOP:

LOCATION OF SPACE:
DESCRIPTION OF SPACE:
DESCRIBE WORK TO BE DONE:

SIGNATURE – CONFINED SPACE SUPERVISOR (1):

SIGNATURE – CONFINED SPACE SUPERVISOR (2) :

ATMOSPHERE: HIGH HAZARD MODERATE HAZARD HIGH HAZARD

COMMUNICATION: RADIO VERBAL VISUAL

LIGHTING : ADEQUATE EXPLOSION PROOF

LOCKOUT REQUIRED: YES NO

If, YES. Lockout – please list all machinery and equipment locked out: _____

- PERSONAL PROTECTIVE EQUIPMENT:**
- STEEL TOE BOOTS
 - RUBBER GLOVES (IMPERMEABLE)
 - RUBBER BOOTS
 - NEOPRENE GLOVES (CHEMICAL)
 - TYVEK COVERALLS (IMPERMEABLE)
 - HALF MASK RESPIRATOR
 - RUBBER COVERALLS (CHEMICAL)
 - ORGANIC VAPOR CARTRIDGES
 - HARD HAT
 - SCBA
 - SAFETY GOGGLES
 - FULL BODY HARNESS / LIFELINE / TRIPOD
 - FACE SHIELD



AIR MONITOR USED:	CALIBRATION DATE:	CALIBRATION DUE DATE:

TIME:	TESTER INITIALS:	OXYGEN (min 19.5% - max 23%)	FLAMMABLE/EXPLOSIVE (max <10% of LEL)	CARBON MONOXIDE (max 8hr average <25ppm)	HYDROGEN SULFIDE (ceiling limit <10ppm)	OTHER: _____

I hereby certify that all required hazard controls are in place, that air monitoring is being conducted as required and results show that the atmosphere is acceptable for entry, and that all required information is documented on this permit.

Tester Signature: _____

Date: _____

Write a “/” each time the named worker enters the space. Write a “\” each time the named worker exits the space – **FORMING AN “X” FOR A COMPLETED ENTRY/EXIT (X)**

Standby Person’s Signature (1): _____ Standby Person’s Signature (2): _____